

Volumetric Feeders, AccuRate Series



- Volumetric feeding of bulk solids
- Feeding without internal agitation
- Gentle material conditioning
- Economical and simple integration
- Compact design

Application

Feeders of the AccuRate series are a special economical solution for volumetric feeding of bulk solids.

With a feed rate range of 0.1 l/h to 8,000 l/h, these feed systems can be used for:

- continuous feeding
- batching and
- blending

of materials with up to 10 mm grain size.

No matter whether materials or additives are fed into the process, extruders or compounders, or a blend requires to be formed, feeders of the AccuRate series offer the right solution for almost any application.

Their simple, compact design does not only ensure easy service and maintenance but also economical integration into existing production plants.

Features

The AccuRate basic feeder comes with the following features:

- Housing (rugged welded structure) of stainless steel, with easily removable side panels
- Flexible hopper of (FDA-approved) TUFLEX vinyl
- “Massaging” paddle system
- Discharge unit (helix and nozzle in stainless steel)
- Vertical discharge head
- Protective grid
- DC or AC drive for helix and paddle (joint or separate)

For DC-drives, a wide choice of controllers is available.

Feed rate and agitation setpoints can be entered via potentiometer, with or without display, for continuous or batch mode. External presetting via analog signal input is also possible.

For optimum adaption of the feed system to the application, beside the basic feeder, a wide choice of feed equipment and accessories is available.

Function

Volumetric AccuRate feeders operate according to the “flexible-wall principle” introduced by Schenck-AccuRate more than 30 years ago.

Instead of the usual internal agitators, all feeders are fitted with two external paddles that gently massage the molded hopper. This ensures a continuous, even flow of material into the helix with a uniform bulk density.

This avoids bridging and material build-up. Additionally, the flexible-wall principle ensures a constantly high filling degree of the helix.

Dimensions

AccuRate Feeder

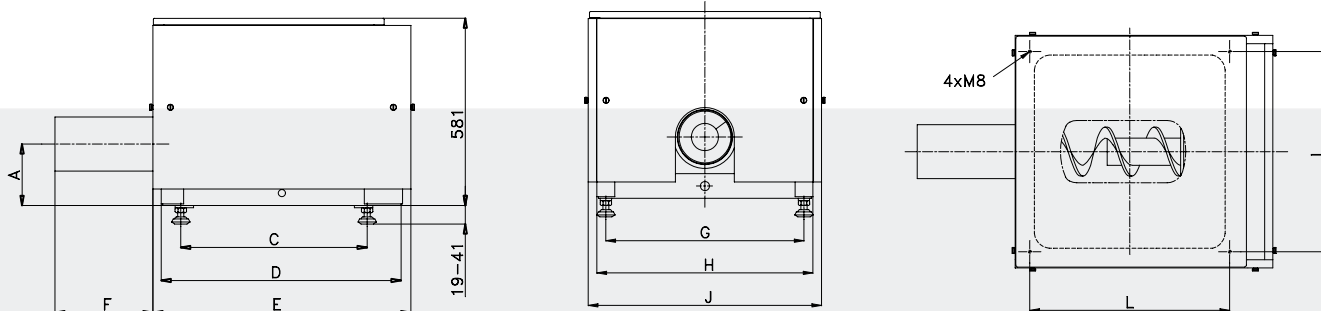

AccuRate Feeder

Fitted With Extension Hopper

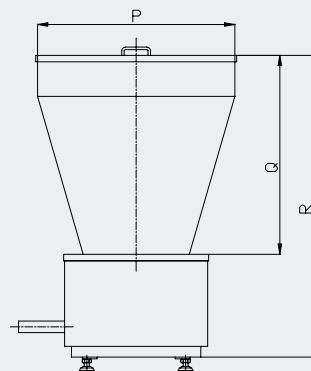
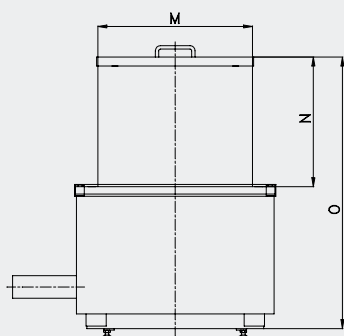

28 l hopper for Series 300
70/140 l hopper for Series 600
140/280 l hopper for Series 900

280 l hopper for Series 600
425 l hopper for Series 900

AccuRate Feeder

Free Standing Hopper

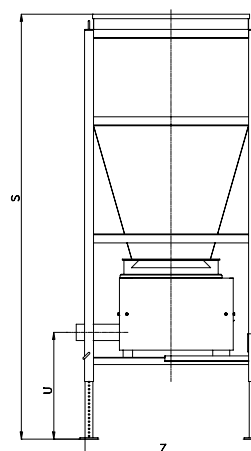
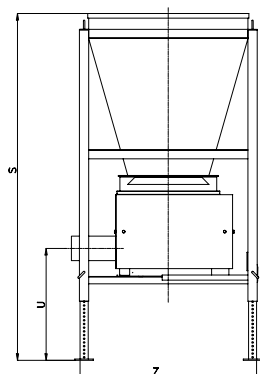

560 l hopper

1420 l hopper

Feeder	Size [mm]									
	A	B	C	D	E	F*)	G	H	J	L
Series 300	86	305	295	330	386	102	267	330	368	305
Series 600	117	400	381	499	552	178	442	499	552	465
Series 900	176	593	470	750	801	305	616	672	725	622

*) Standard size; other lengths available as an option

Hopper - Fitted	Size [mm]					
	M	N	O	P	Q	R
Series 300 - 8 liters	283	362	664			
Series 600 - 70 liters - 140 liters - 280 liters	432 432	362 718	762 1118	762	1118	1168
Series 900 - 140 liters - 280 liters - 425 liters	584 584	413 870	1006 1463	914	672	1265

Hopper – Free Standing	Size [mm]		
	S	U	Z
Series 600 - 560 liters 1420 liters	2020, 2325, 2360, 2935 2604, 2909, 3213, 3519	587, 892, 1197, 1502	1220 1220
Series 900 - 560 liters - 1420 liters	2020, 2325, 2360, 2935 2604, 2909, 3213, 3519	557, 762, 1067, 1372	1220 1220

Technical Data

AccuRate Feeders

Series	300	600	900
Maximum feed rate	~0.1 l/h – 105 l/h	1 l/h – 1.300 l/h	30 l/h – 8.000 l/h
Setting range	1 : 50		
Flexible hopper capacity - without extension hopper	9 dm ³	25 dm ³	75 dm ³
Helix diameter - available	Ø 6, 10, 13, 19, 25 mm	Ø 13, 19, 25, 35, 45, 57 mm	Ø 57, 76, 102 mm
Helix standard length - from feeder front	102 mm	178 mm	305 mm
Maximum helix extension	~ 300 mm	~ 1.220 mm	~ 1.220 mm
Drive motor	0.09 kW DC 0.09 kW AC	0.18 kW DC 0.18 kW AC	0.55 kW DC 1.1 / 1.5 kW AC
Motor protected to	IP 54		
Supply voltage	230 V (AC)	230 V (AC)	230 V / 400 V (AC)
Weight	~ 30 kg	~ 65 kg	~ 145 kg
Ambient temperature	- 20°C bis + 40°C		
Material temperature	max. 80°C		
Bulk density	$\gamma \sim 0.1 - 3 \text{ kg/l}$		
Grain size	up to 10 mm		
Flow properties	free flowing to sluggish		

Accuracy

The normal accuracy achieved with AccuRate feeders is between ± 1.5 and 2.5% of setpoint.

Additional Requirements

The variants and options described in this brochure are only a small part of the AccuRate feeders program. Should you have specific needs, e.g. for:

- special hopper designs for the food and pharmaceutical industries
- dust-tight connection to BIG-BAG stations
- extension hoppers for manual bag discharge

... please tell us your requirements.

Order Data

To be able to process your order smoothly and quickly, please let us know the application data below.

Material Data

Material.....
 Material density..... [kg/l]
 Grain size..... [mm]
 Flow properties.....

Feed Rate Range

from [kg/h]
 to [kg/h]

Drive Design

AC drive

DC drive

Extension Hopper

Volume [l]

Should you order an option which requires size or length to be indicated, please specify in your order.

AccuRate Feeders – Series 300

Basic Variants

Basic variants,

including discharge unit (helix and nozzle) in standard design (diameter depending on feed rate)

- DC drive (0.09 kW) including power controller with digital potentiometer in stainless steel housing
- AC drive (0.09 kW for 3 x 230V) without drive control

Variants

Dual drive

Separate drive motor to be used with sluggish materials, big extension hoppers, big feed rate range (> 5:1) and helix extended to > 50% of standard length

- DC version – separate DC drive and extended control
- AC version – separate AC drive

Quick-disconnect system,

for easy exchange of flexible hopper in case of frequent cleaning or product change

Food/pharmaceutical industries design (to FDA and USDA)

With sealed bearings, ground welds, polished helix, flexible (white) hopper and quick-disconnect system

Control Options for DC motors

Control with Potentiometer

Display and Touchpad Potentiometer

Wall-mounting housing for control system

IP65 in carbon steel painted or stainless steel

Analog input, 4-20 mA / 0-10V

Feeder control via external setpoint

Batch timer, for setting of batching time, volumetric mode

Remote start/stop contact

Feed Unit/ Tube Options (length and size to be indicated in your order)

Additional discharge unit (helix and nozzle),

for extension of feed rate range in particular standard length (Series300: 102 mm) diameter in accordance with desired feed rate extension

Helix and nozzle extension, to max. 300 mm

Stainless steel; length (from feeder front) to be specified in your order

Nozzle support with Series 300, we recommend support for stainless steel downturn.

Side nozzle discharge, for flushing material, to improve feeding constancy

Outlet shut-off gate, pneumatically actuated, suitable for batching

Stainless steel Dust Elbow (in place of vinyl)

Extension Hoppers, Stainless Steel

28 liters

AccuRate Feeders – Series 600

Basic Variants

Basic variants,

including discharge unit (helix and nozzle) in standard design (diameter depending on feed rate)

- DC drive (0.18 kW) including power controller with digital potentiometer in stainless steel housing
- AC drive (0.18 kW for 3 x 230V) without drive control

Variants

Dual drive

Separate drive motor to be used with sluggish materials, big extension hoppers, big feed rate range (> 5:1) and helix extended to > 50% of standard length

- DC version – separate DC drive and extended control
- AC version – separate AC drive

Quick-disconnect system,

for easy exchange of flexible hopper in case of frequent cleaning or product change

Food/pharmaceutical industries design (to FDA and USDA)

With sealed bearings, ground welds, polished helix, flexible (white) hopper and quick-disconnect system

Control Options for DC motors

Control with Potentiometer

Display and Touchpad Potentiometer

Wall-mounting housing for control system

IP65 in carbon steel painted or stainless steel

Analog input, 4-20 mA / 0-10V

Feeder control via external setpoint

Batch timer, for setting of batching time, volumetric mode

Remote start/stop contact

Feed Unit/ Tube Options (length and size to be indicated in your order)

Additional discharge unit (helix and nozzle),

for extension of feed rate range in particular standard length (Series 600: 178 mm) diameter in accordance with desired feed rate extension

Helix and nozzle extension, to max. 1220 mm

Stainless steel; length (from feeder front) to be specified in your order

Nozzle support with Series 600, we recommend min. 300 mm length or if a stainless steel dust elbow is used.

Side nozzle discharge, for flushing material, to improve feeding constancy

Outlet shut-off gate, pneumatically actuated, suitable for batching

Stainless steel Dust Elbow (in place of vinyl)

Extension Hoppers, Stainless Steel

70 liters; fitted onto feeder

140 liters; fitted onto feeder

280 liters; fitted onto feeder

560 liters; free standing

1420 liters; free standing

AccuRate Feeders – Series 900

Basic Variants

Basic variants,

including discharge unit (helix and nozzle) in standard design (diameter depending on feed rate)

- DC drive (0.55 kW) including power controller with digital potentiometer in stainless steel housing
- AC drive (1.1 / 1.5 kW for 3 x 230V or 3 x 400V) without drive control

Variants

Dual drive

Separate drive motor to be used with sluggish materials, big extension hoppers, big feed rate range (> 5:1) and helix extended to > 50% of standard length

- DC version – separate DC drive and extended control
- AC version – separate AC drive

Quick-disconnect system,

for easy exchange of flexible hopper in case of frequent cleaning or product change

Food/pharmaceutical industries design (to FDA and USDA)

With sealed bearings, ground welds, polished helix, flexible (white) hopper and quick-disconnect system

Control Options for DC motors

Control with Potentiometer

Display and Touchpad Potentiometer

Wall-mounting housing for control system

IP65 in carbon steel painted or stainless steel

Analog input, 4-20 mA / 0-10V

Feeder control via external setpoint

Batch timer, for setting of batching time, volumetric mode

Remote start/stop contact

Feed Unit/ Tube Options (length and size to be indicated in your order)

Additional discharge unit (helix and nozzle),

for extension of feed rate range in particular standard length (Series 900: 305 mm) diameter in accordance with desired feed rate extension

Helix and nozzle extension, to max. 1220 mm

Stainless steel; length (from feeder front) to be specified in your order

Nozzle support with Series 900, we recommend min. 400 mm length or if a stainless steel dust elbow is used.

Side nozzle discharge, for flushing material, to improve feeding constancy

Outlet shut-off gate, pneumatically actuated, suitable for batching

Stainless steel Dust Elbow (in place of vinyl)

Extension Hoppers, Stainless Steel

140 liters; fitted onto feeder

280 liters; fitted onto feeder

425 liters; fitted onto feeder

560 liters; free standing

1420 liters; free standing

Theoretical Federates

All mentioned feed rates are theoretical feed rates based on a filling efficiency of 100 %. In practice the filling efficiency can be reduced by 20 – 30 %, depending on material properties and application.

Open Helix [l/hr]														
Helix O.D. [mm]	Pitch [mm]	Sizes by Series			Helix Speed [rpm]									
		300	600	900	1	10	20	40	60	80	100	120	140	160
13	6,5				0,0374	0,374	0,748	1,50	2,24	2,99	3,74	4,49	5,24	5,98
13	13				0,0784	0,784	1,57	3,14	4,71	6,27	7,8	9,4	11,0	12,5
19	9,5				0,133	1,33	2,65	5,31	7,96	10,6	13,3	15,9	18,6	21,2
19	19				0,296	2,96	5,91	11,8	17,7	23,6	29,6	35,5	41,4	47,3
25	12,5				0,303	3,03	6,06	12,1	18,2	24,3	30,3	36,4	42,5	48,5
25	25				0,689	6,89	13,8	27,6	41,4	55,1	68,9	82,7	96,5	110
35	17,5				0,850	8,50	17,0	34,0	51,0	68,0	85,0	102	119	136
35	35				1,85	18,5	37,1	74,1	111	148	185	222	259	296
44	22				1,83	18,3	36,6	73,1	110	146	183	219	256	293
44	44				3,90	39,0	77,9	156	234	312	390	468	546	624
57	28,5				4,04	40,4	80,8	162	242	323	404	485	566	646
57	57				8,46	84,6	169	338	507	677	846	1015	1184	1353
76	38				9,26	92,6	185	371	556	741	926	1112	1297	1482
76	76				19,7	197	394	788	1181	1575	1969	2363	2756	3150
102	102				50,4	504	1007	2015	3022	4029	5036	6044	7051	8058

Helix With Center Rod [l/hr]														
Helix O.D. [mm]	Pitch [mm]	Sizes by Series			Helix Speed [rpm]									
		300	600	900	1	10	20	40	60	80	100	120	140	160
6	6				0,0067	0,0677	0,135	0,271	0,406	0,541	0,677	0,812	0,948	1,08
10	10				0,0188	0,188	0,375	0,750	1,13	1,50	1,88	2,25	2,63	3,00
13	6,5				0,0253	0,253	0,507	1,01	1,52	2,03	2,53	3,04	3,55	4,05
13	13				0,0543	0,543	1,09	2,17	3,26	4,34	5,4	6,5	7,6	8,7
19	9,5				0,060	0,60	1,21	2,41	3,62	4,8	6,0	7,2	8,4	9,6
19	19				0,151	1,51	3,02	6,0	9,1	12,1	15,1	18,1	21,1	24,1
25	12,5				0,249	2,49	4,97	9,9	14,9	19,9	24,9	29,8	34,8	39,8
25	25				0,580	5,80	11,6	23,2	34,8	46,4	58,0	69,6	81,2	93
35	17,5				0,698	6,98	14,0	27,9	41,9	55,8	69,8	84	98	112
35	35				1,55	15,5	31,0	61,9	93	124	155	186	217	248
44	22				1,45	14,5	29,0	57,9	87	116	145	174	203	232
44	44				3,14	31,4	62,7	125	188	251	314	376	439	502
57	28,5				2,69	26,9	53,8	108	161	215	269	323	376	430
57	57				5,74	57,4	115	230	345	459	574	689	804	919
76	38				8,11	81,1	162	324	486	648	811	973	1135	1297
76	76				17,4	174	347	695	1042	1390	1737	2085	2432	2779
102	102				44,5	445	890	1781	2671	3562	4452	5343	6233	7124