

MULTICOR[®] S – Mass Flow Measuring

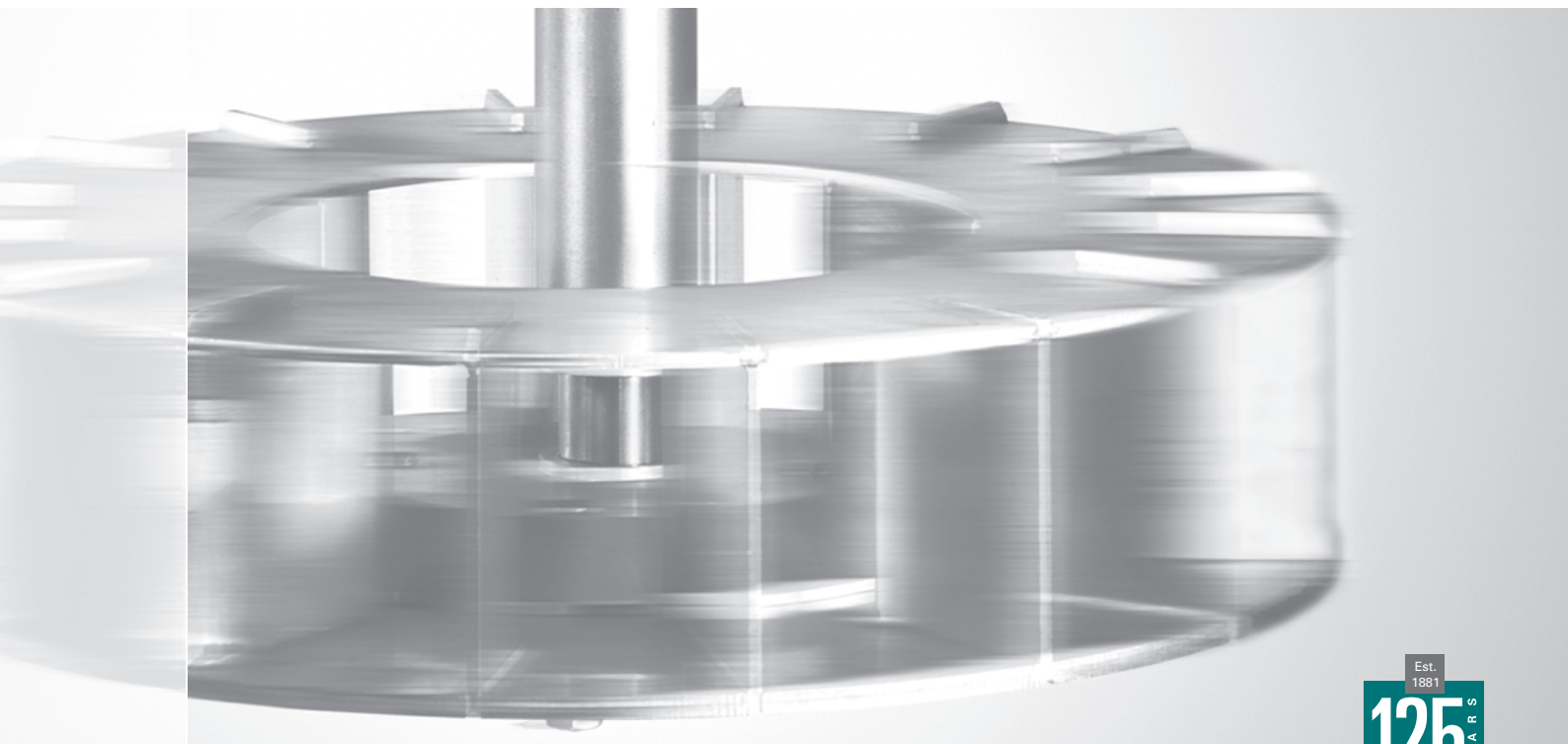

MULTICOR[®] S – Mass Flow Meters and Feeders
with Highly Accurate Coriolis Technology



Everything Accurately Measured and Fed

Whenever it comes to continuous metering, control and feeding of significant material amounts, the MULTICOR® S Mass Flow Meters and Feeders are the systems of choice.

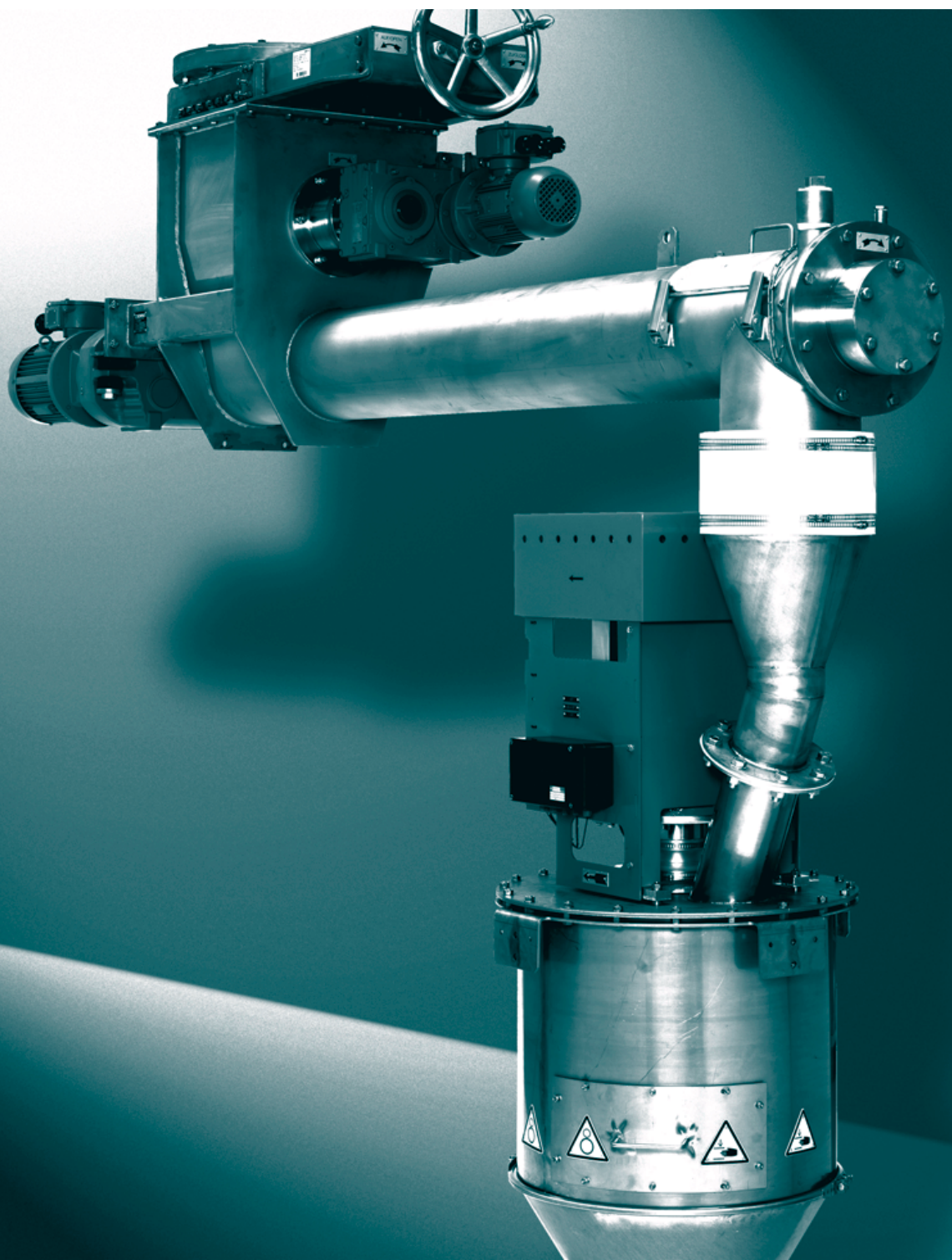

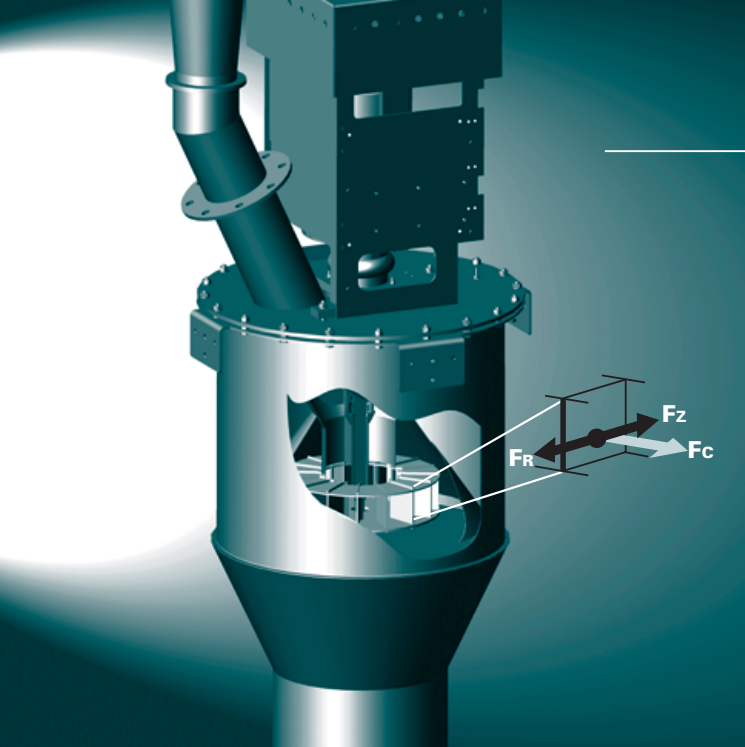

MULTICOR® S operating principle

Mass Flow Measurement with Coriolis Force

The material enters into the MULTICOR®'s rotating measuring wheel in free fall. Through centrifugal force, the material particles are forced outward along the guide vanes. On the measuring wheel - through the acceleration in circumferential direction - the Coriolis force acts on the material. As a measured variable, this force is directly proportional to the gravimetric feed rate also with varying bulk density and grain size.

Definition of forces:

F_c = Coriolis force

F_R = Frictional force

F_z = Centrifugal force

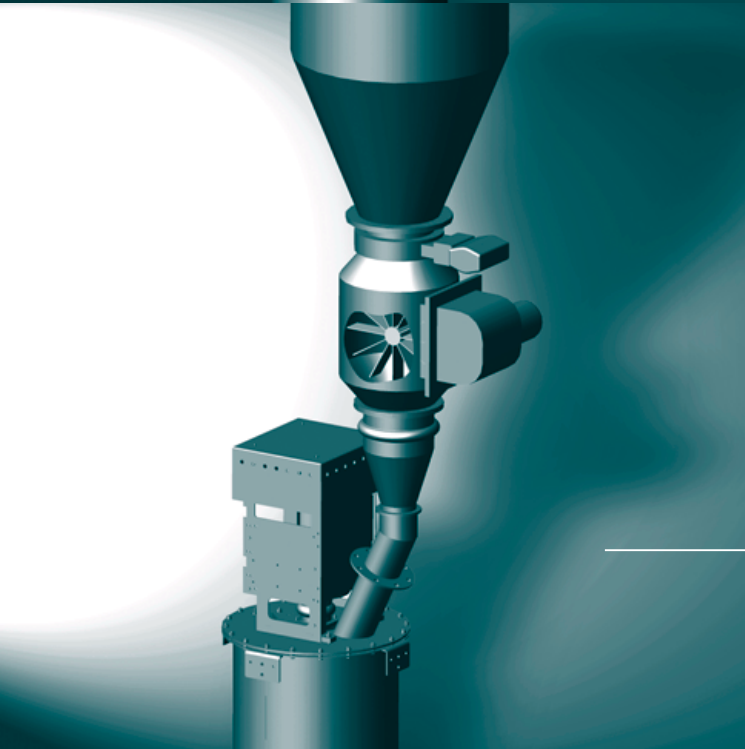

Compatible, Flexible, Accurate

Equipped with a controlled prefeeder, a screw or rotary feeder, the MULTICOR® S system is ideal for feeding applications with the highest demands on accuracy.

For measurement value, the INTECONT® Plus or DISOCONT® weighing electronics are available. The combination of MULTICOR® S and DISOCONT® in MechaTronic design can be directly coupled to any commercial host system via fieldbus connection.

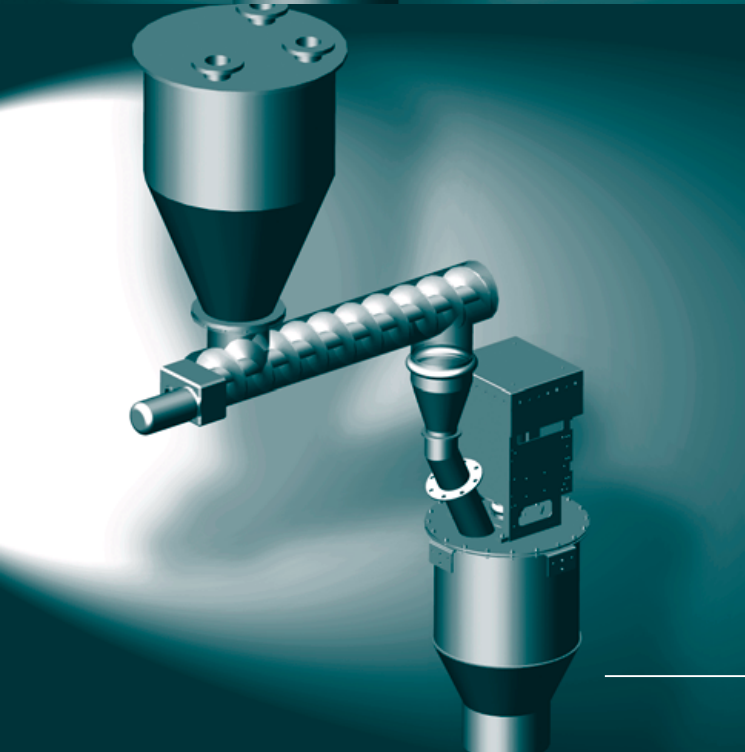

MULTICOR® S with rotary feeder

MULTICOR® S is designed as an enclosed measuring system for metering feed rate and process data accurately and economically. By applying Coriolis technology, $\pm 0.5\%$ accuracy and repeatability can be achieved. Through Coriolis technology, the Schenck Process MULTICOR® S system handles balancing, batching, blending, throughput and consumption measurement.

- ❖ High measuring and feeding accuracy of $\pm 0.5\%$ related to actual feed rate
- ❖ Easy installation through direct incorporation into material flow
- ❖ Low maintenance costs
- ❖ Not affected by external conditions
- ❖ Dust-tight stainless steel offering

MULTICOR® S with feed screw

Typical applications:

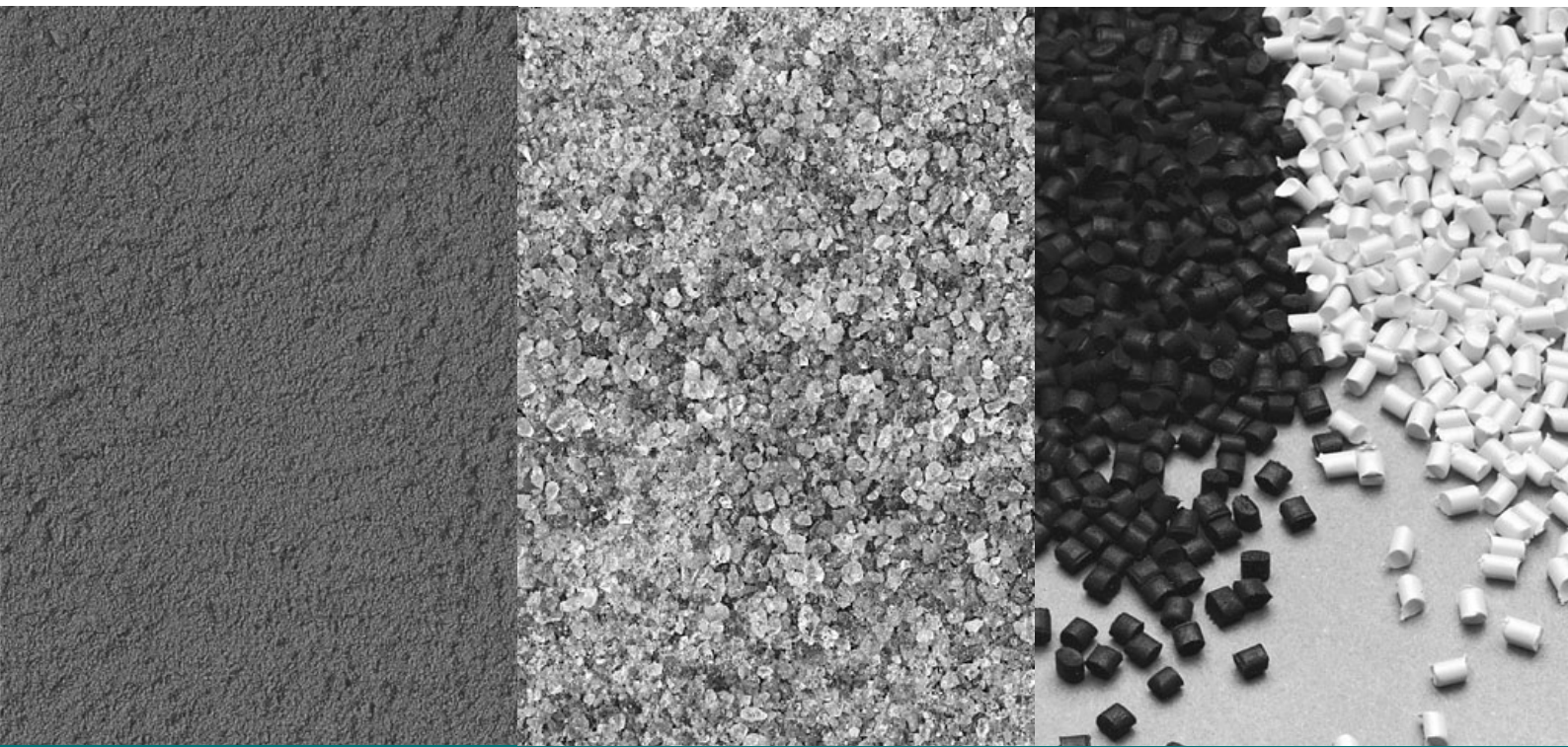

- ❖ Feeding of polymer powders for the manufacture of basic plastic resins
- ❖ Granules flow measurement
- ❖ Feeding of TPA powders in polyester plants
- ❖ Measurement of the flow of grain in mills
- ❖ Mass flow metering in in-plant transport, and in the detergent and fertilizer industries



PASS:

Customised to meet your requirements, our comprehensive Process Advanced Service System provides you with the best service:

- ❖ Service around-the-clock
- ❖ Over 30 service points
- ❖ Over 180 service specialists
- ❖ Expert training for customers

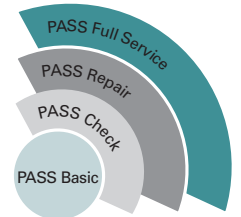

To make the lives of our customers as simple as possible, our service products have been split into 4 levels that reflect the various stages of the product life cycle and enable us to provide a targeted customer service.

MULTICOR® S

Below you will find an overview of the various types of configurations and feed rate ranges of the MULTICOR® S measuring and feeding systems

Feed Rate Range				
Type	S 40	S 80	S 160	S 260
Max. vol. feed rate	40 m ³ /hr	80 m ³ /hr	160 m ³ /hr	260 m ³ /hr
Max. mass flow	20 t/hr	60 t/hr	150 t/hr	100 t/hr
Basic Configuration				
Type	S 40	S 80	S 160	S 260
Max. material temperature	130° C	130° C	130° C	130° C
Adm. operating pressure	20 mbar	20 mbar	20 mbar	20 mbar
Accuracy	± 0.5 %	± 0.5 %	± 0.5 %	± 0.5 %
Inspection hole				
Stainless steel configuration				
Options				
Type	S 40	S 80	S 160	S 260
Explosion-proof gas/dust configuration				
Wear protection / lining Measuring wheel / system				
Inert gas blanket				

Highest Quality and Precision

Precision and quality is the cornerstone of our corporate philosophy. This is illustrated through the design of our MULTICOR® systems and our comprehensive service concept. Strict quality control prior to shipment, installation and commissioning along with a proactive after-sales support program reinforce our commitment to precision and quality.

weighing

feeding

measuring

automation

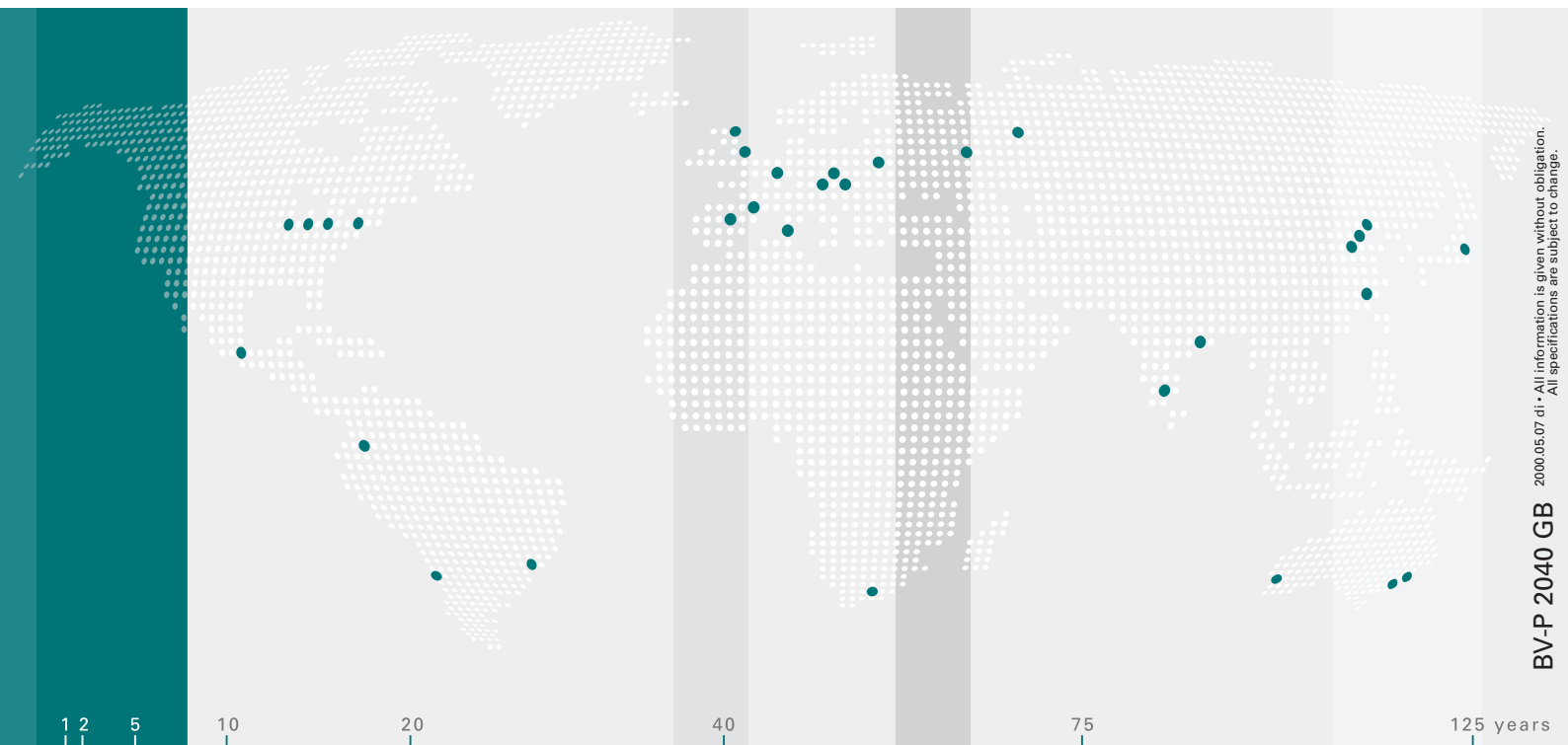

BV-P 2040 GB 2000.05.07 dt • All information is given without obligation. All specifications are subject to change.

Schenck Process is the global market leader of solutions in measuring and process technologies in industrial weighing, feeding, measuring and automation.

Schenck Process develops, manufactures and markets a full range of solutions, products and turnkey systems on the basis of combining process engineering expertise, reliable components and field-proven technology.

Schenck Process GmbH
 Pallaswiesenstr. 100
 64293 Darmstadt, Germany
 T +49 61 51-32 11 19
 light@schenckprocess.com
 www.schenckprocess.com

we make processes work

© by Schenck Process GmbH, 2007