

Riera Nadeu 

ENGINEERED IN  
BARCELONA  
1952





**ABOUT US**

- Innovation from Barcelona
- Worldwide presence with 2.000+ installations
- Quality equipment since 1952

ENGINEERED IN  
**BARCELONA**  
1952

Riera Nadeu



**RINA BRAND**

- Taylor made projects
- Low maintenance machines
- Energy efficient solutions

ENGINEERED IN  
**BARCELONA**  
1952

Riera Nadeu



riera   
www.riera.na

**SUPERCENTRIFUGES**

- RINA SRP
- RINA SRPB

ENGINEERED IN  
**BARCELONA**  
1952

## RINA SRP

---

### Innovations

- Sterilizable.
- ATEX & explosión proof versión
- Full opening doors
- Massive stainless-Steel frame

### Benefits

- Reliable, simple and compact design
- High G factor
- Low maintenance cost

### Clients

**GRIFOLS**

**Baxter**

**omrix**  
Biopharmaceuticals Ltd.  
a Johnson & Johnson company



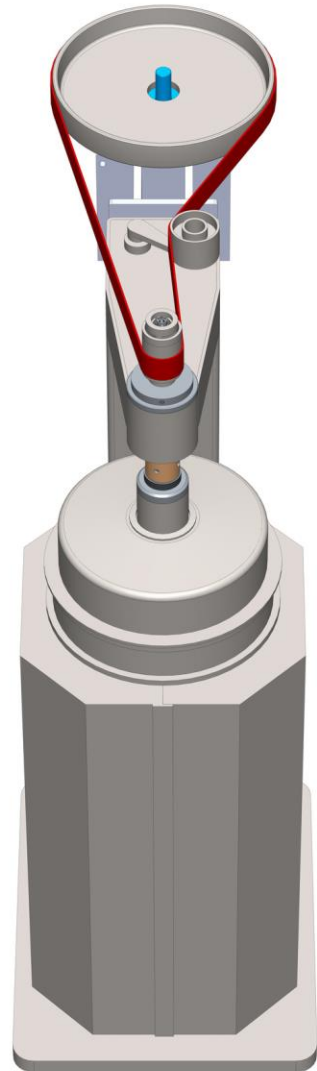

**RINA SRP**

- 100% accessibility
- Full opening body
- Easy maintenance
- Massive stainless-steel frame

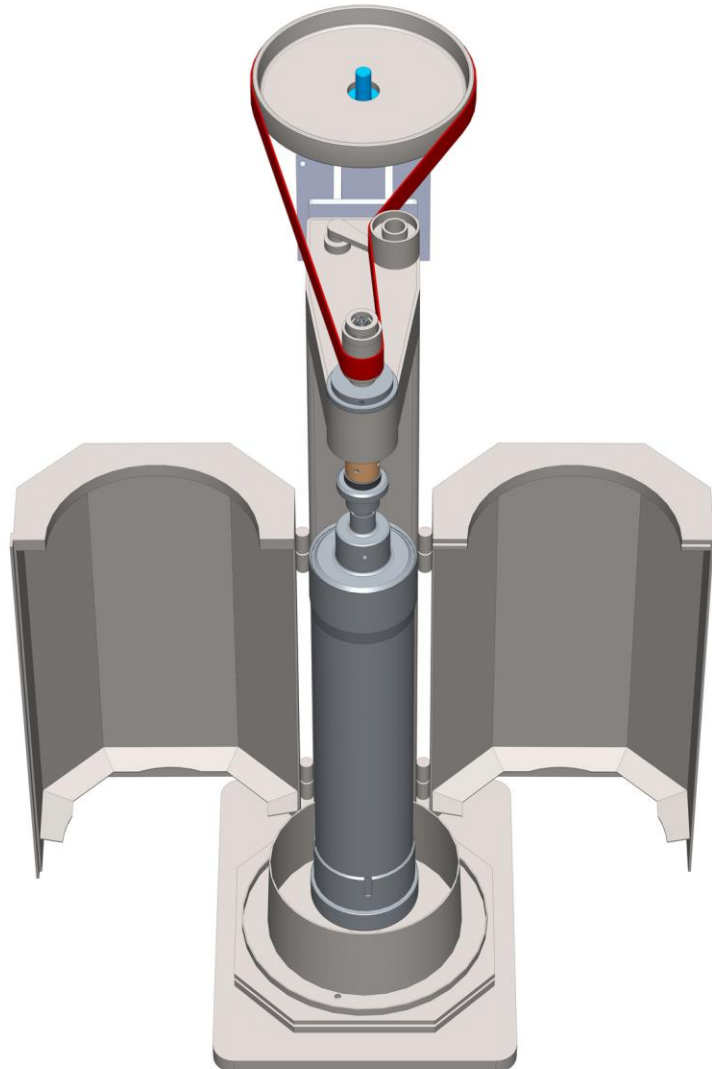
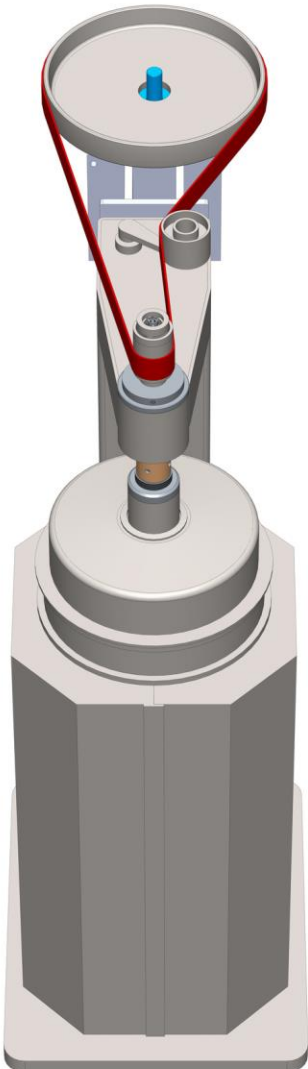

**RINA SRP**

- 100% accessibility
- Full opening body
- Easy maintenance
- Massive stainless-steel frame

ENGINEERED IN  
**BARCELONA**  
1952

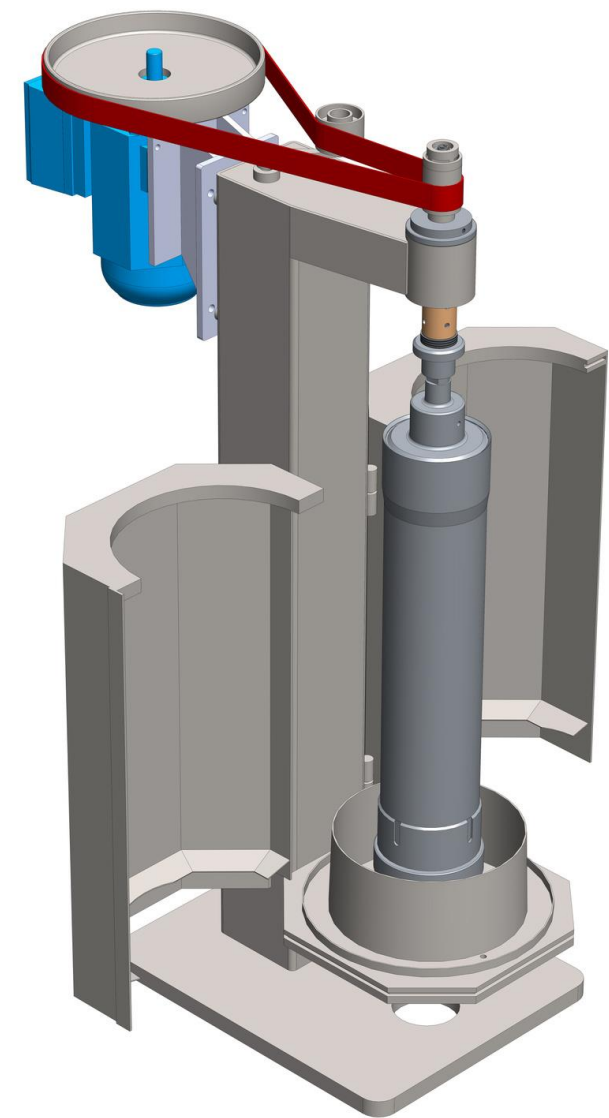
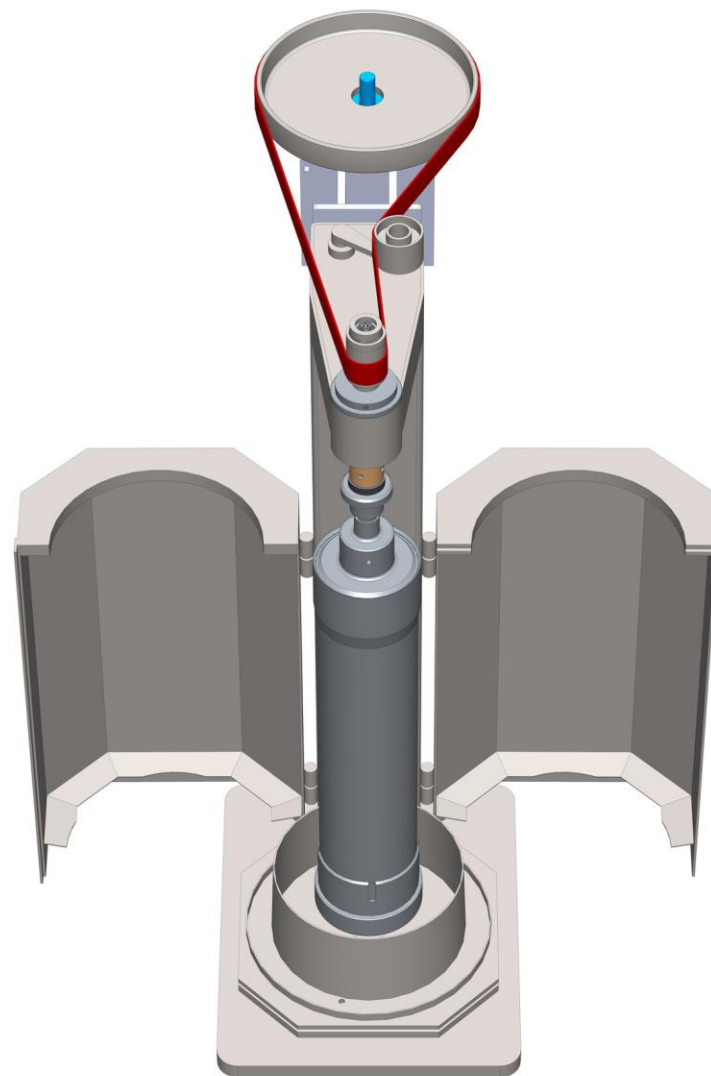
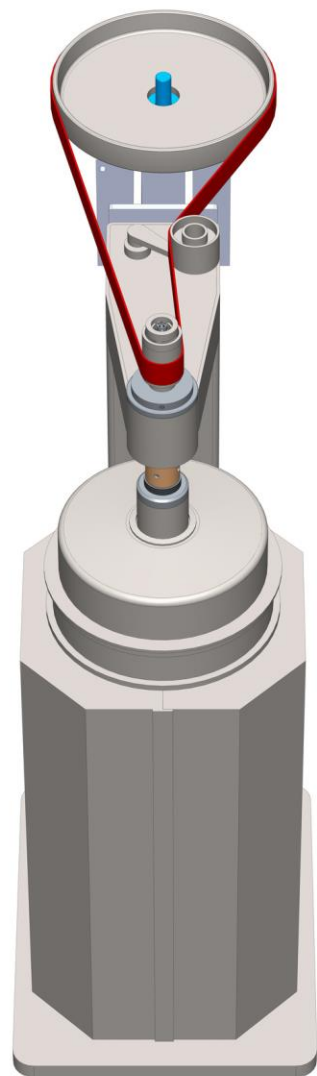

**RINA SRP**

- 100% accessibility
- Full opening body
- Easy maintenance
- Massive stainless-steel frame

ENGINEERED IN  
**BARCELONA**  
1952

Riera Nadeu



**RINA SRP**

**omrix**  
Biopharmaceuticals Ltd.  
a *Johnson & Johnson* company

ENGINEERED IN  
**BARCELONA**  
1952

**Process**

- Feeding
- Inlet
- Outlet
- Mother liquor outlet

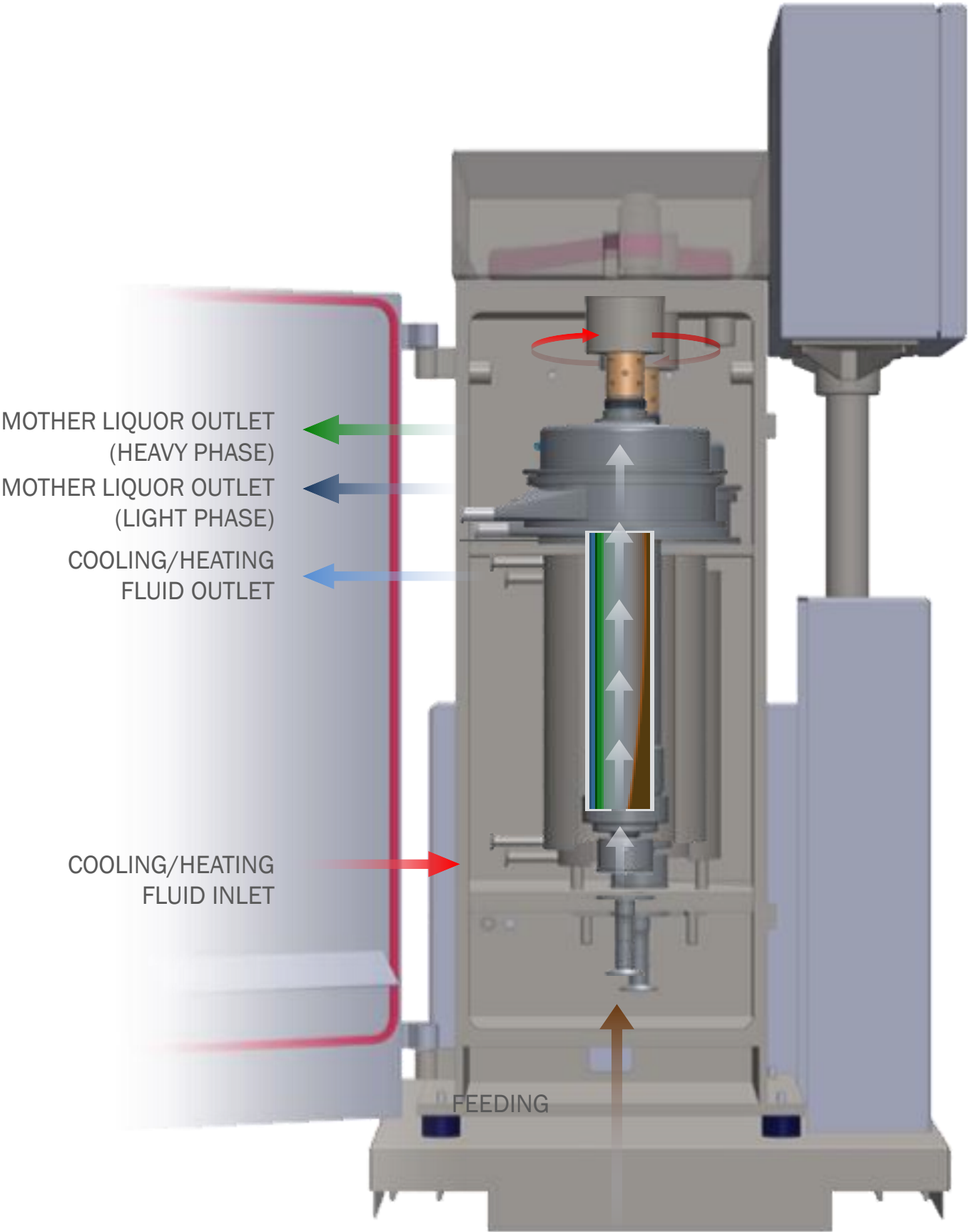

## Features

- Integrated in box
- Easy opening panels for 100% accessibility
- Full opening gate
- Easy maintenance
- Massive stainless-steel frame
- Noise reduction
- Cleaner solution
- Possible cleaning in place installation
- ATEX version available



Riera Nadeu 



**RINA SRPB**



ENGINEERED IN  
**BARCELONA**  
1952

MODELS	Bowl Ø mm	Bowl Heigh Ø mm	Volume Lts.	Speed Rpm	G FACTOR	Motor Power Hp	Bowl Ø inch	Bowl Heigh Ø inch	Volume Cu. Ft.
<b>SRPB 0,25</b>	45	200	0,22	25000	15625	0,5	1,77	8	0,01
<b>SRPB 3</b>	85	420	2,03	18000	15300	1	3,35	16	0,07
<b>SRP / SRPB 5</b>	105	735	5,44	16000	15000	3	4,13	29	0,19
<b>SRP / SRPB 8</b>	125	735	7,73	14700	15000	5	4,92	29	0,27
<b>SRP/ SRPB 10</b>	145	735	9,88	13700	15000	5,5	5,71	29	0,35



**CIRCULAR ECONOMY**

- Long-term cooperation during the whole life cycle of your projects



**Riera Nadeu** 

 C/Leonard Torres Quevedo, 17-23, 08403 Granollers, Barcelona

 [administration@rieranadeu.com](mailto:administration@rieranadeu.com) · [commercial@rieranadeu.com](mailto:commercial@rieranadeu.com)

 +34 93 840 70 72 / Mon-Thurs: 7:45 h – 17:15h / Fri: 7:45 h – 15:00h

**BARCELONA**  
ENGINEERED IN  
1952